



## B300PBA

### Fender Mounting Instructions for MIN300 & MIN318

#### **STEP 1**

- A. Unpack all cartons and lay out parts.
- B. Compare the parts with hardware kit B300PBA as shown in Figure 1.

PART NUMBER	DESCRIPTION	QTY.
PB5030	26" PADDLE BRACKET	4
PB5054	PADDLE BKT CLMP 2 1/4 ACCUSEAL	4
I31N125WFEZ	5/16X1 1/4 FENDER WASHER Z	24
I31C100BSF/RBZ	5/16-18 X 1 HEX WASHER HEAD BL	32
I31N150WFEZ	5/16 X 1 1/2 FENDER WASHER	32
I31CNCN/RBZ	5/16-18 CLASS G FLANGE LOCK	32
I31C62BSF/NPAT	5/16-18x5/8 Serr Flange Bolt Z	24
PB5019	SWIVEL BRACKET W 5.75" PIPE	4
I62C450BFL8/RB2FT	5/8"-11 x 4 1/2" HEX FLANGE BOLT	4
I62CNCN/RB2	5/8"-11 CLASS G FLANGE LOCK N	4
PB1/2"SPACER	1/2" POLY SPACER	12
PB2011	STEELE WELD ON BKT	4



Figure 1

#### **STEP 2**

- A. Lay the fenders out and clamp them together (Figure 2). This will make bolting them together much easier.



Figure 2

- B. The lip of both fenders needs to be cut off to accommodate the center support bracket (PB2011).
- This will be the side of the fenders that is closest to the truck frame.
  - Place a mark 3" in from the end of each fender (Figure 3).



Figure 3

- C. Draw an outline of the area that needs to be cut out similar to Figure 4.
- Cut out the area marked in Figure 4.

Figure 4



- D. Make sure the center bracket and trim plate (if purchased) are centered between the two fenders (Figure 5).

**Tip:** The center bracket (PB2011) v should be facing down.

- Drill eight 5/16" holes through fender and trim plate from the bottom using the holes in the center bracket (PB2011) as a pattern.
- Use eight 5/16" x 1" bolts to bolt the fenders, trim plate, and center bracket together.
- Use eight 5/16" nuts provided with the kit on the underside of the fenders.
- Tighten the 5/16" x 1" bolts to a recommended torque of 10-15 ft-lbs.**

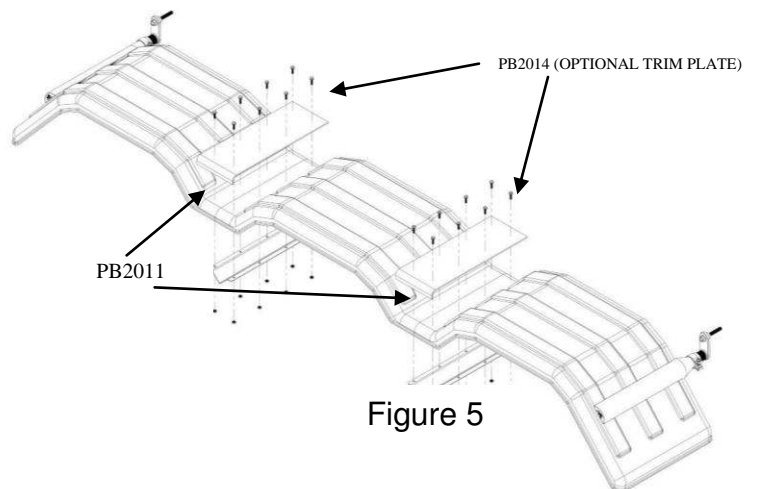

Figure 5

**Tip:** Start with the bolts closest to the truck frame and work towards the outside.

### STEP 3

- A. Measure the suspension travel. This measurement is used to determine the distance between the fender and the wheel.
  - a. For air suspension systems, let the air out of the air bags.
  - b. For spring systems, measure from the stops on the springs to the bottom of the frame.

**NOTE: For air suspensions with travel exceeding 6”:**

In some cases a travel stop may need to be installed to prevent such large gaps between the fenders & tires. This will help with alignment and 5<sup>th</sup> wheel plate clearance. (Please call *Minimizer@ 800-248-3855* for questions regarding this issue).

- B. Gap the fenders  $\frac{3}{4}$ ” over the maximum travel point of the suspension system. The goal is to make sure the fender does not rub on the tire. A gap larger than  $\frac{3}{4}$ ” may be necessary if using worn tires.

**TIP:** Establish the  $\frac{3}{4}$ ” minimum gap required in Step 3B.

- a. For an air suspension system, place a  $\frac{3}{4}$ ” board on top of the tires after the air has been let out of the airbags (Figure 6). Place the fender on top of the board.
- b. For a spring suspension system, add  $\frac{3}{4}$ ” to the measurement from Step 3A.

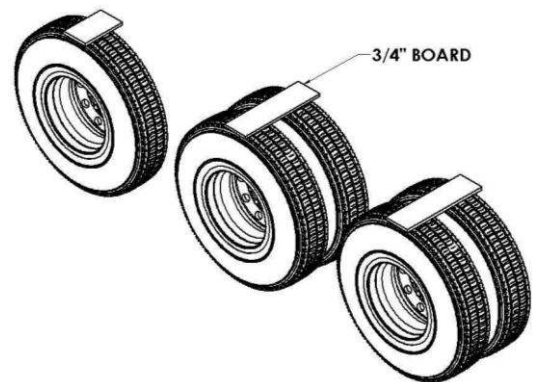

Figure 6

### STEP 4

- A. Position the fenders exactly where they will be mounted.
- B. Insert the paddle bracket (PB5030) onto a swivel bracket (PB5019) as shown in Figure 7.
- C. Hold the bracket assembly over top of the fenders and against the truck frame to visually mark the locations where the brackets will bolt to the frame.

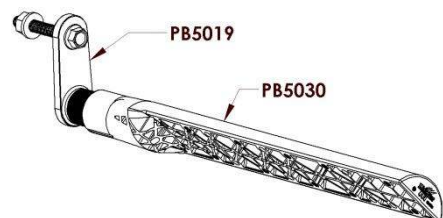

Figure 7

- a. Try to use existing holes in the frame to bolt through. It is possible to remove any existing frame bolt and replace it with the supplied bolt in the bracket kit.

**Tip:** It is common for the front bracket to align with the existing quarter fender holes and the rear bracket to align with the holes left from the mud flap hanger.



b. When possible it is best to bolt the steel swivel bracket directly to the frame as shown in Figure 8. There are two mounting holes in the swivel bracket to choose from. If using the mounting hole inside the pipe as shown in Figure 8 the excess flat steel may be trimmed off to provide a cleaner look.

c. For situations where frame components are in the way of the PB5019 swivel bracket, trim off the pipe component of the swivel bracket and substitute a round spacer to gain clearance around the obstruction.



Figure 8

i. If spacers are required, determine the minimum number of spacers needed to clear the obstruction.

ii. Trim off the pipe of the PB5019 to provide room for the spacers. There are three lines cut in to the pipe to act as a guide. See Figure 9 for a detailed view.

**NOTE: Use spacers only when necessary.**

Trim PB5019 on the appropriate guide line when using 1, 2, or 3 spacers.

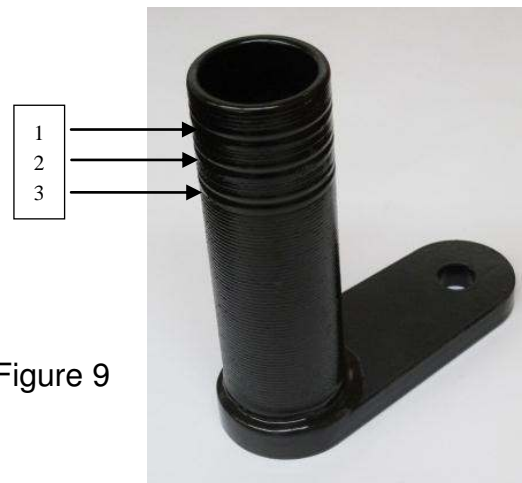

Figure 9

- D. Make sure the brackets are within 15" of the bottom of the leading edge of the fender to prevent wind from blowing the fender back into the tire (Figure 10).

**Tip:** If the front fender bracket is mounted higher than 15", refer to:  
<http://www.minimizer.com/instructions.html> for further suggestions on adding additional support.

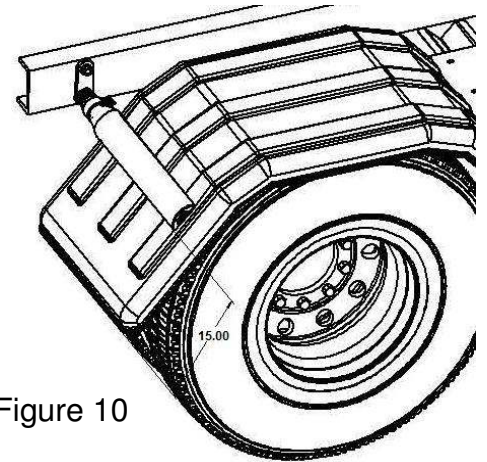

Figure 10

## **STEP 5**

- A. Bolt the remaining PB5019 swivel brackets to the truck frame as shown in Figure 11 and tighten the nut so the brackets suit the desired position of the fender. **Recommended torque for the 5/8" X 4-1/2" bolts is 160-170 ft-lbs**
- B. Slide the PB5030 brackets onto the PB5019 swivel brackets that are mounted to the frame.  
a. **Make sure the base end of the PB5030 is fully engaged into the PB5019.**
- C. Rotate the PB5030 so it makes good contact with the fender.

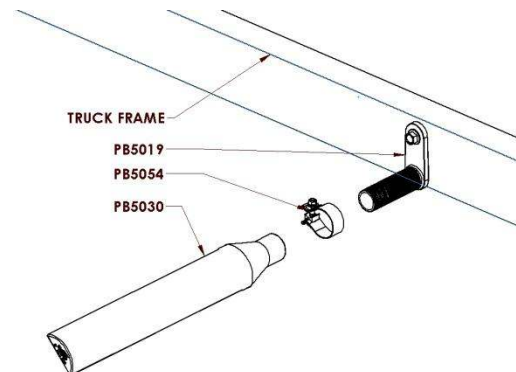

Figure 11

**NOTE: ONCE FENDERS ARE IN SERVICE, OCCASIONALLY CHECK TORQUE ON THE 5/8" X 4-1/2" HEX BOLTS IN THE FRAME TO MAKE SURE THEY DO NOT LOOSEN OVER TIME.**

## **STEP 6**

- A. Attach drilling template.  
a. Unpack the provided paper drilling templates that match the PB5030 bracket as shown in Figure 12.

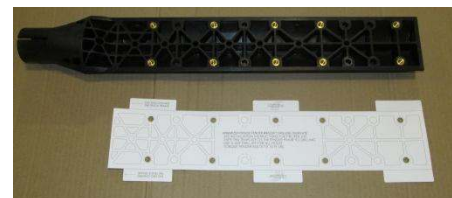

Figure 12

- b. Insert the drilling template between the fender and PB5030 bracket as shown in Figure 13 and align it with the edges of the bracket.
- c. Verify that the fenders are resting square and aligned over the tire. Twists or bows in the fender will fatigue the material over time.



Figure 13

- d. Apply tape to the tabs of the template and secure the tape to the ribs of the fender as shown in Figure 14.
- e. Remove the fender from the wheels and confirm that all templates are secure.



Figure 14

#### B. Drill Mounting Holes for PB5030

- a. Drill six 3/8" holes through the fender. Use the paper template as a guide at the locations circled below (Figure 15). One template is provided for every PB5030 bracket.

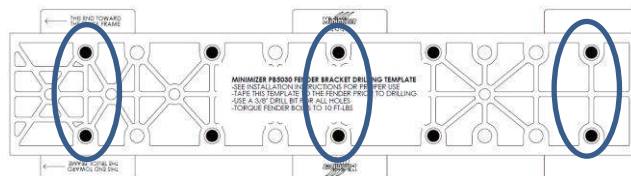

Figure 15

### STEP 7

#### A. Attach the PB5030 bracket to the fender.

- a. With the bracket separated from the truck, install six 5/16" x 5/8" bolts and fender washers through the fender and into the bracket. **Turn each bolt approximately 2 full turns. Do not fully tighten.** See Figure 16 below.

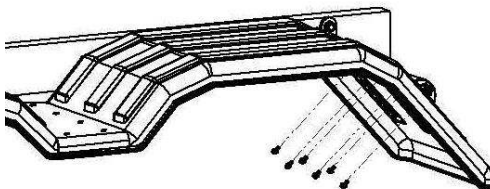

Figure 16



## **STEP 8**

- A.** Attach the fender and PB5030 to the PB5019 swivel.
- Carefully lift the fender & bracket assembly with PB5054 tube clamp over the tire and slide the PB5030 brackets on to the PB5019 swivel brackets mounted on the frame.
  - Position the PB5054 tube clamp 1/4" inside the edge of the paddle bracket as shown in Figure 17.
  - Torque the tube clamp to 50 ft-lbs. using a 15mm wrench or deep well socket.**
  - Figure 18 below shows a close up view of a properly torqued PB5054 tube clamp.

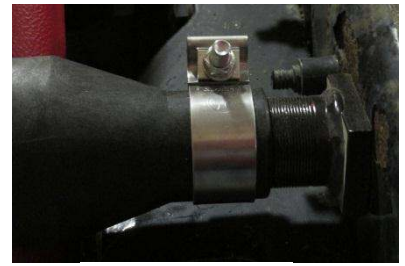

Figure 17



Figure 18

## **STEP 9**

- A.** Tighten all 5/16" x 5/8" fender bolts to 10 ft lbs. Impact wrenches are not recommended.

## **STEP 10**

- A.** The center bracket PB2011 will be attached to the truck frame. It is possible to bolt a plate (not supplied) to the frame and weld the brackets to that plate (Figure 19). Another option is to weld the bracket directly to the frame.
- Plate should be a minimum of 1/4" thick steel.
  - Suggested plate dimensions are 8" x 8" x 1/4".

**Tip: Check owner's manual before welding directly to the frame. Most manufacturers do not suggest welding anything directly to the frame.**

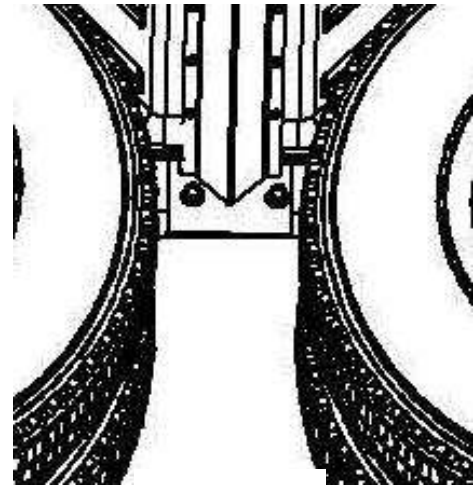

Figure 19

## **STEP 11**

- A.** For trucks with air suspension raise and lower the suspension one final time to confirm that there is adequate clearance between the fenders and wheels.