



## B600PBA

### Fender Mounting Instructions for MINTA1554, MINTA910, MINTF1554 & MINTF900 Fenders

#### STEP 1

- A. Unpack all cartons and lay out parts.
- B. Compare the parts with hardware kit B600PBA as shown in Figure 1.

PART NUMBER	DESCRIPTION	QTY
PB5019	5.75" SWIVEL BRACKET	4
I62C450BFL8/RBZFT	5/8-11 X 4 1/2 HEX FLANGE BOLT	4
I62CNCG/RBZ	5/8-11 CLASS G FLANGE LOCK N	4
PB1/2"SPACER	1/2" POLY SPACER	12
PB5030	26" PADDLE BRACKET	4
PB5054	PADDLE BKT CLMP 2 1/4 ACCUSEAL	4
I31C62BSF/NPAT	5/16-18X5/8 SERR FLANGE BOLT Z	24
I31N125WFEZ	5/16X1 1/4 FENDER WASHER Z	24
PB5067	STEEL ANGLE FOR PB5069	4
I62C250BFL8/RBZ	5/8-11 X 2 1/2 HEX FLG BOLT BZ	4
I62CNCG/RBZ	5/8-11 CLASS G FLANGE LOCK N	4
PB1/2"SPACER	1/2" POLY SPACER	4
PB5069	COMPOSITE CENTER BRACKET	4
I31C125BSF/RBZ	5/16-18 X 1 1/4 HEX WASH HEAD B	16
I31CNCNCF/RBZ	5/16-18 CLASS F FLANGE LOCK	16
PB5071	COMPOSITE ANGLE FOR PB5069	4
I31C125BSF/RBZ	5/16-18 X 1 1/4 HEX WASH HEAD B	28
I31CNCNCF/RBZ	5/16-18 CLASS F FLANGE LOCK	28
I31C100BSF/RBZ	5/16-18 X 1 HEX WASHER HEAD BL	16
I31CNCNCF/RBZ	5/16-18 CLASS F FLANGE LOCK	16
I31N150WFEZ	5/16 X 1 1/2 FENDER WASHER	32



Figure 1

#### STEP 2

- A. Lay the fenders out and clamp them together depending if the fender style is MINTA (Figure 2) or MINTF (Figure 3). This will make bolting them together much easier.



MINTA

Figure 2



MINTF

Figure 3

### **STEP 3**

- A. Bolt the fenders together A pack of 5/16" x 1" bolts, 5/16" nuts and 5/16" x 1-1/2" fender washers is included in the kit. Use four bolts per joint and torque bolts to 10-15 ft-lbs.
- B. In some cases PMTF44 or PMTA53 will need to be cut down to accommodate a shorter amount of tire coverage.
- C. Cut the end of the center section off and clamp PMTF44EC to the unfinished end of the fender (Figure 4).
  - a. PMTF44EC can be used with either TF44 or TA53.
- D. Drill five 1/4" holes through the fender using the holes in PMTF44EC as a guide.

- E. Use five 1/4" x 3/4" Phillips truss head bolts and lock nuts to connect the fenders as shown in Figure 4.

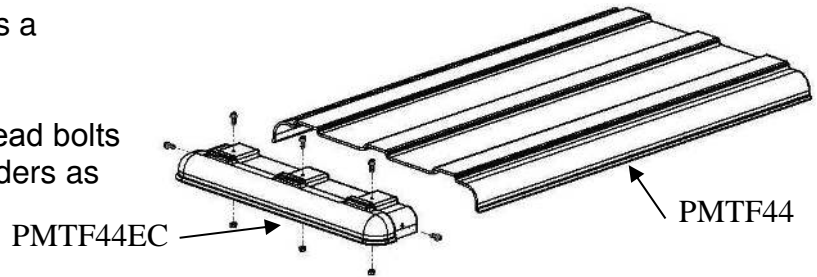

- a. This is an add on hardware kit that is separate from the bracket kit.

Figure 4

### **STEP 4**

- A. Measure the suspension travel. This measurement is used to determine the distance between the fender and the wheel.
  - a. For air suspension systems, let the air out of the air bags.
  - b. For spring systems, measure from the stops on the springs to the bottom of the frame.

**NOTE: For air suspensions with travel exceeding 6":**

In some cases a travel stop may need to be installed to prevent such large gaps between the fenders & tires. This will help with alignment and 5<sup>th</sup> wheel plate clearance. *(Please call Minimizer @ 800-248-3855 for questions regarding this issue).*

- B. Gap the fenders 3/4" over the maximum travel point of the suspension system. The goal is to make sure the fender does not rub on the tire. A gap larger than 3/4" may be necessary if using worn tires.

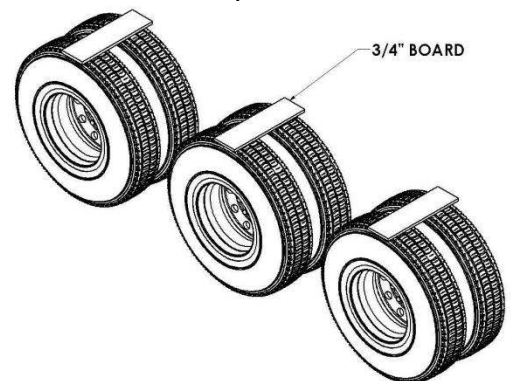

**TIP:** Establish the 3/4" minimum gap required in Step 4B.

- a. For an air suspension system, place a 3/4" board on top of the tires after the air has

been let out of the airbags (Figure 5).  
Place the fender on top of the board.

b. For a spring suspension system, add  $\frac{3}{4}$ "  
to the measurement from Step 4A.

Figure 5

## **STEP 5**

A. Position the fenders over the tires exactly where they will be mounted.

B. Insert the PB5030 Paddle Bracket onto a  
PB5019 swivel bracket as shown in Figure 6.

C. Hold the bracket assembly over top of the  
fenders and against the truck frame to visually  
mark the locations where the brackets will bolt to  
the frame.

a. Try to use existing holes in the frame to  
attach the PB5019. It is possible to remove  
any existing frame bolt and replace it with the  
supplied bolt in the bracket kit.

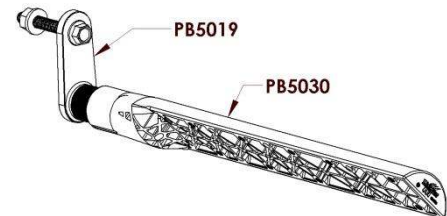

Figure 6

**Tip:** It is common for the front bracket to align  
with the existing quarter fender holes and the  
rear bracket to align with the holes left from the  
mud flap hanger.

**NOTE:** Depending on the length of the truck  
frame and the placement of the mud flap  
hangers, the fender may tuck inside the mud flap  
hanger. Figure 7 shows a truck with flaps and  
fenders.



Figure 7

**NOTE: When installing any fender equipped with  
a built in light box do not drill into the weld or any  
other part of the light box. If a mud flap is  
mounted to the light box style fender and the mud  
flap is backed over, it may cause the interior  
welded plate to become loose. Slot the mud flaps to  
prevent this issue. This is NOT covered under  
warranty. Figure 8 shows an example of a lightbox  
fender equipped with mud flaps.**



Figure 8

- b. Where possible it is best to bolt the steel swivel bracket directly to the frame as shown in Figure 9. There are two mounting holes in the swivel bracket to choose from. If using the mounting hole inside the pipe as shown in Figure 9 the excess flat steel may be trimmed off to provide a cleaner look.

- c. For situations where frame components are in the way of the PB5019 swivel bracket, trim off the pipe component of the swivel bracket and substitute a round spacer to gain clearance around the obstruction.



Figure 9

- i. If spacers are required, determine the minimum number of spacers needed to clear the obstruction.
- ii. Trim off the pipe of the PB5019 to provide room for the spacers. There are three lines cut in to the pipe to act as a guide. See Figure 10 for a detailed view.

**NOTE: Use spacers only when necessary.**

Trim PB5019 on the appropriate guide line when using 1, 2, or 3 spacers.

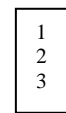

Figure 10

- D. If possible position the bracket within 15” of the bottom of the leading edge of the fender to avoid wind blowing the fender back into the tire (Figure 11).

**Tip:** If the front fender bracket is mounted higher than 15”, refer to <http://www.minimizer.com/instructions.html> for further suggestions on adding additional support.

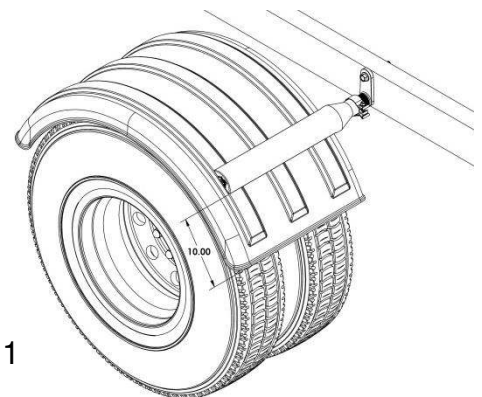

Figure 11

## STEP 6

- A. Bolt the remaining PB5019 swivel brackets to the truck frame as shown in Figure 12 and tighten the nut so the brackets suit the desired position of the fender. **Recommended torque for the 5/8" x 4-1/2" bolts is 160-170 ft-lbs.**
- B. Slide the PB5030 brackets onto the PB5019 swivel brackets that are mounted to the frame.
- a. **Make sure the base end of the PB5030 is fully engaged into the PB5019.**
- C. Rotate the PB5030 so it makes good contact with the fender.

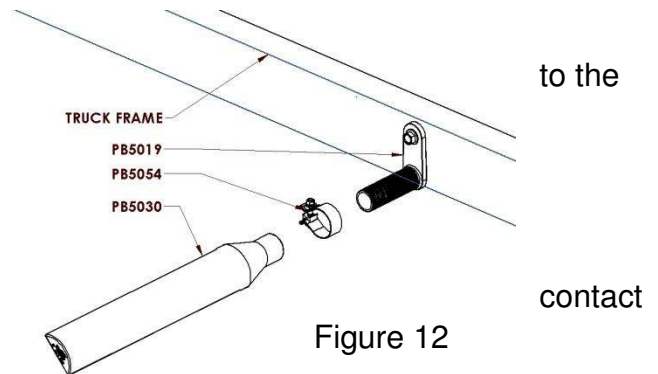

Figure 12

**NOTE: OCCASIONALLY CHECK THE 5/8" X 4-1/2" HEX BOLTS ON THE FRAME TO MAKE SURE THEY DO NOT LOOSEN OVER TIME.**

## STEP 7

- A. Install center bracket assembly (Figure 13).
- a. Try to use existing holes in the frame to bolt through. It is possible to remove any existing frame bolt and replace it with the supplied bolt in the bracket kit. **Recommended torque for the 5/8" x 2-1/2" bolt with washer is 110-115 ft-lbs.**

See IMPORTANT assembly instructions for center bracket PB5069 & PB5067, last page of this form.

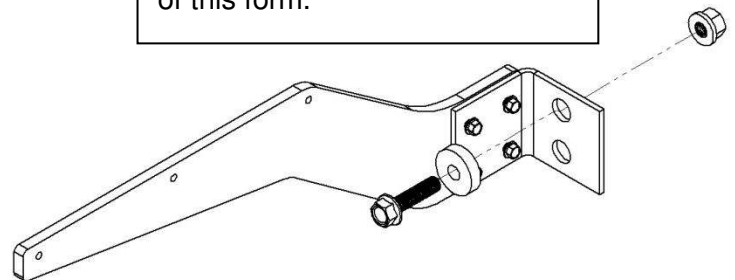

Figure 13

- B. Install center bracket as close to where the fenders join together as possible (Figure 14).
- a. Drill three 5/16" holes through the fenders using the holes in bracket PB5069 as a guide.
- b. Use three 5/16" x 1 1/4" bolts to bolt the center bracket and fenders together.
- c. Use 5/16" fender washers and 5/16" nuts provided with the kit on the inside of the fenders. **Recommended torque for all 5/16" hardware is 10-15 ft-lbs.**

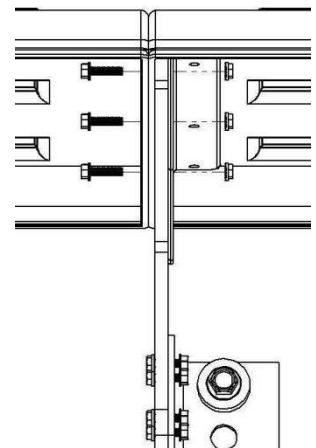

Figure 14

C. Some installations may not allow the center bracket to bolt through the ends of the fenders.

- a. In these cases use the plastic angle (PB5071) to connect the fenders to the center bracket assembly (Figure 15).
- b. Use three 5/16" x 1" bolts, washers, and nuts to bolt PB5071 to the center bracket assembly. Do not tighten these until the fender assembly is level.

**Recommended torque is 10-15 ft-lbs.**

**Tip:** PB5071 is also used as a height adjustment for the fender assembly.

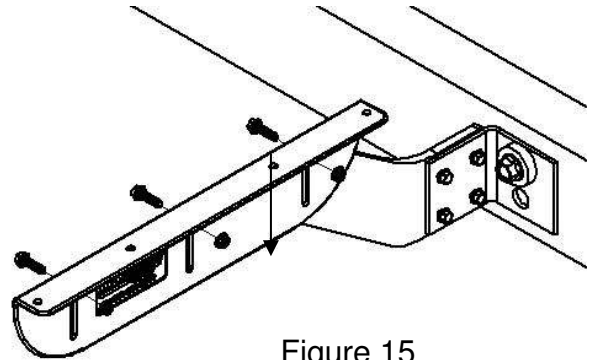

Figure 15

D. Drill four 5/16" holes through the fender using the holes in bracket PB5071 as a guide (Figure 16).

- a. Install the 5/16" x 1 1/4" bolts through the bracket and into fender.
- b. Use 5/16" body washers and 5/16" nuts provided with the kit the underside of the fender.
- c. Each bracket kit includes an 8 pack of 1" bolts, 5/16" nuts, and 5/16" x 1 1/2" fender washers to bolt the fenders together.

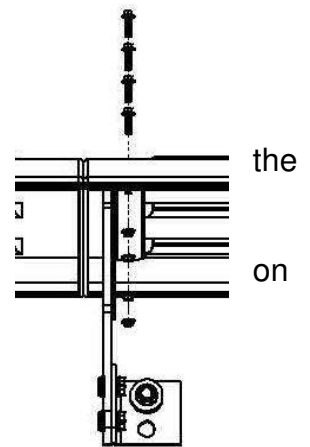

Figure 16

## **STEP 8**

A. Attach drilling template.

- a. Unpack the provided paper drilling templates that match the PB5030 bracket as shown in Figure 17.



Figure 17

- b. Insert the drilling template between the fender and PB5030 bracket as shown in Figure 18 and align it with the edges of the bracket.
- c. Verify that the fenders are resting square and aligned over the tire. Twists or bows in the fender will fatigue the material over time.



Figure 18

- d. Apply tape to the tabs of the template and secure the tape to the ribs of the fender as shown in Figure 19.
- e. Remove the fender from the wheels and confirm that all templates are secure.



Figure 19

- B. If using the optional PBTF44EC, make sure to mount PB5030 far enough from the end so it doesn't interfere with the bolts used for PBTF44EC (Figure 20).

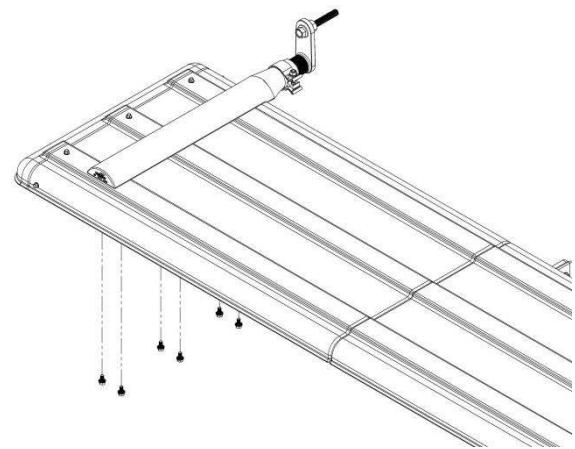

Figure 20

- C. Drill Mounting Holes for PB5030.

- a. Drill six 3/8" holes through the fender. Use the paper template as a guide at the locations circled below in Figure 21. One template is provided for every PB5030 bracket.

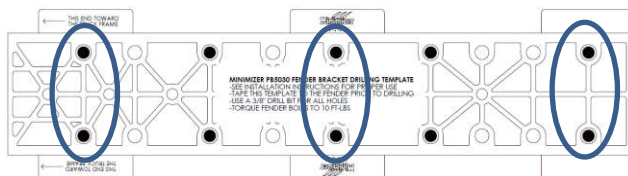

Figure 21

## **STEP 9**

- A. Attach the PB5030 bracket to the fender.

- a. With the bracket separated from the truck, install six 5/16" x 5/8" bolts and fender washers through the fender and into the bracket. **Turn each bolt approximately 2 full turns. Do not fully tighten.** See Figure 22 below.

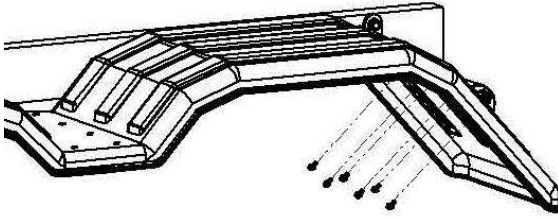

Figure 22

## **STEP 10**

- A. Attach the fender and PB5030 to the PB5019 swivel.
- Carefully lift the fender & bracket assembly with PB5054 tube clamp over the tire and slide the PB5030 brackets on to the PB5019 swivel brackets mounted on the frame.
  - Position the PB5054 tube clamp 1/4" inside the edge of the paddle bracket as shown in Figure 23.
  - Torque the tube clamp to 50 ft-lbs using a 15mm wrench or deep well socket.**
  - Figure 24 is a close up view of a properly PB5054 torqued tube clamp.

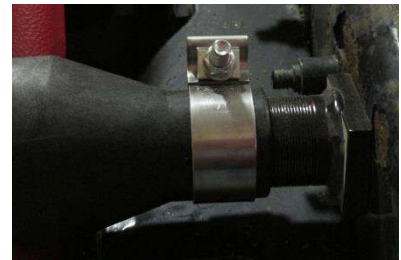

Figure 23



Figure 24

## **STEP 11**

- A. **Tighten all 5/16" x 5/8" fender bolts to 10 ft-lbs. Impact wrenches are not recommended.**

## **STEP 12**

- A. For trucks with air suspension raise and lower the suspension one final time to confirm that there is adequate clearance between the fenders and wheels.



