



100128

Fender Mounting Instructions for MIN4000, MIN900, MIN1500 & MIN1554 Fenders

STEP 1

- A. Unpack all cartons and lay out parts.
- B. Compare the parts with hardware kit 100128 as shown in Figure 1.

PART NUMBER	DESCRIPTION	QTY
PB5015	BRKT,5015,STL,SWVL,4.25,BLK	4
I62C450BFL8/RBZFT	HDWR,HHCS,RBZ,FLNG,5/8-11X4.5	4
I62CNCG/RBZ	HDWR,NUT,RBZ,FLNG-LOCK,5/8-11	6
PB1/2"SPACER	HDWR,SPCR,PE,.5	14
100133	BRKT,5010,PP,TPRD,26,SLVMIR	4
100366	BRKT,BLOCK,PP-MICA,BLK	4
I31C300BSF	HDWR,HHCS,ZINC,SERR,5/16-18X3	16
I31C100BSF	HDWR,HHCS,ZINC,SERR,5/16-18X1	24
I31N150WFEZ	HDWR,WSHR,ZINC,5/16X1.5	40
I31CNCZFZ	HDWR,NUT,FLNG-LOCK,5/16-18	54
PB5067	BRKT,5067,STL,CNTR,ANGL	2
I62C250BFL8/RBZ	HDWR,HHCS,RBZ,FLNG,5/8-11X2.5	2
PB5069	BRKT,5069,PE,CNTR,.5	2
I31C125BSF/RBZ	HDWR,HHCS,RBZ,SERR,5/16-18X1.2	8
I31CNCF/RBZ	HDWR,NUT,RBZ,FLNG-LOCK,5/16-18	8
PB5071	BRKT,5071,PE,CNTR,ANGL	2
I31C125BSF	HDWR,HHCS,ZINC,5/16-18X1.25	14
I31C100BSF/RBZ	HDWR,HHCS,RBZ,SERR,5/16-18X1	8
I31CNCF/RBZ	HDWR,NUT,RBZ,FLNG-LOCK,5/16-18	8

100128 Mounting Kit



Figure 1

WARNING:

DO NOT APPLY CHROME POLISH, METAL POLISH, OR ANY TYPE OF BUFFER TO MINIMIZER SILVER MIRROR PRODUCTS. USING ANY OF THE ABOVE ITEMS WILL VOID PRODUCT WARRANTY.

- Protective wrap has been applied to protect the brackets during shipment.
- Wash brackets with mild soap and water.
- Do not wipe the mirror finish when it is dry or with a dry cloth. Only use a clean, damp microfiber cloth when wiping or drying your Minimizer Silver Mirror products.
- Do not use any abrasive cleaners or pads.
- Care for Minimizer Silver Mirror products as you would care for an automotive paint finish.
- To maintain the luster of Minimizer Silver Mirror products, apply an off the shelf wax/polish combination that you would use on the painted surfaces of your automobile. Follow the manufacturer’s instructions on the product of your choice e.g. “Meguiars”, “Mothers Gold”, “Blue Coral”.

STEP 2

- A. Lay the fenders out and clamp them together (Figure 2). This will make bolting them together much easier.
- B. Bolt the fenders together. A pack of 5/16 x 1" bolts, 5/16" nuts and 5/16" x 1- 1/2" fender washers is included in the kit. **Use four bolts per joint. Recommended torque is 10-15 ft-lbs.**



Figure 2

STEP 3

- A. Measure the suspension travel. This measurement is used to determine the distance between the fender and the wheel.
 - a. For air suspension systems, let the air out of the air bags.
 - b. For spring systems, measure from the stops on the springs to the bottom of the frame.

NOTE: For air suspensions with travel exceeding 6":

In some cases a travel stop may need to be installed to prevent such large gaps between the fenders & tires. This will help with alignment and 5th wheel plate clearance. (Please call *Minimizer* @ 800-248-3855 for questions regarding this issue).

- B. Gap the fenders 3/4" over the maximum travel point of the suspension system. The goal is to make sure the fender does not rub on the tire. A gap larger than 3/4" may be necessary if using worn tires.

TIP: Establish the 3/4" minimum gap required in Step 3B.

- a. For an air suspension system, place a 3/4" board on top of the tires after the air has been let out of the airbags (Figure 3). Place the fender on top of the board.
- b. For a spring suspension system, add 3/4" to the measurement from Step 3A.

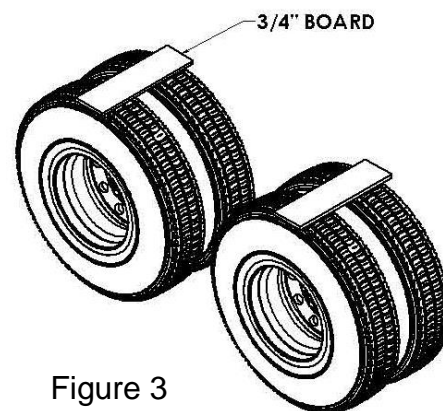

Figure 3

STEP 4

- A. Position the fenders exactly where they will be mounted.
 - a. Visually pick and mark the locations that the brackets will bolt to the frame.
- B. Try to use existing holes in the frame to bolt through. It is possible to remove any existing frame bolt and replace it with the supplied bolt in the bracket kit.

Tip: It is common for the front bracket to align with the existing quarter fender holes and the rear bracket to align with the holes left from the mud flap hanger.

NOTE: Depending on the length of the truck frame and the placement of the mud flap hangers, the fender may tuck inside the mud flap hanger. Figure 4 shows a truck with flaps and fenders.



Figure 4

NOTE: Do not drill into the weld or any other part of the light box. If a mud flap is mounted to the light box style fender and the mud flap is backed over, it may cause the interior welded plate to become loose. Slot the mud flaps to prevent this issue. This is NOT covered under warranty.



- C. Spacers are supplied to bring the steel swivel away from the frame in the event of any obstructions (Figure 5).
 - c. The ideal setup is to mount the steel swivel directly to the frame.

NOTE: Use spacers only when necessary.

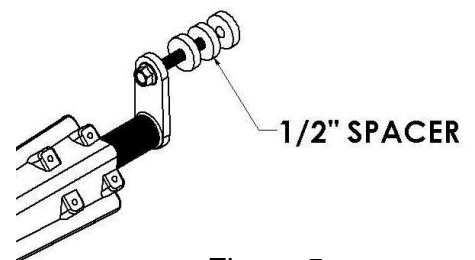

Figure 5

- D. Install center bracket assembly (Figure 6).
 - a. Try to use existing holes in the frame to bolt through. It is possible to remove any existing frame bolt and replace it with the supplied bolt in the bracket kit.
Recommended torque for the 5/8 x 2-1/2\"/>

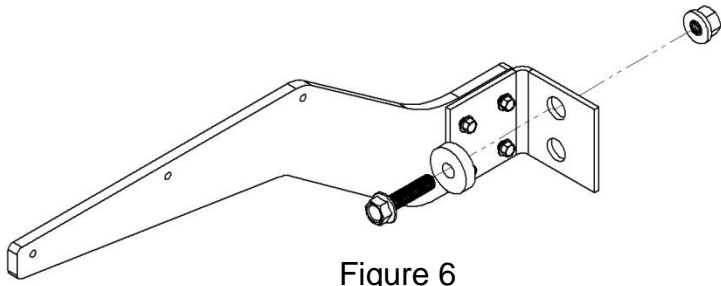

Figure 6

See **IMPORTANT** assembly instructions for center bracket PB5069 & PB5067, last page of the form.

E. Install center bracket as close to where the two fenders join together as possible (Figure 7).

- a. Drill three 5/16" holes through the fenders using the holes in bracket PB5069 as a guide.
- b. Use three 5/16" x 1 1/4" bolts to bolt the center bracket and fenders together. **Recommended torque for all 5/16" hardware is 10-15 ft-lbs.**
- c. Use 5/16" fender washers and 5/16" nuts provided with the kit on the inside of the fenders.

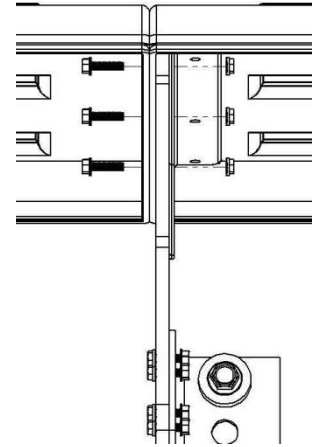

Figure 7

F. Some installations may not allow the center bracket to bolt through the ends of the fenders.

- a. In these cases use the plastic angle (PB5071) to connect the fenders to the center bracket assembly (Figure 8).
- b. Use three 5/16" x 1" bolts, washers, and nuts to bolt PB5071 to the center bracket assembly. Do not tighten these until the fender assembly is level. **Recommended torque is 10-15 ft-lbs.**

Tip: PB5071 is also used as a height adjustment for the fender assembly.

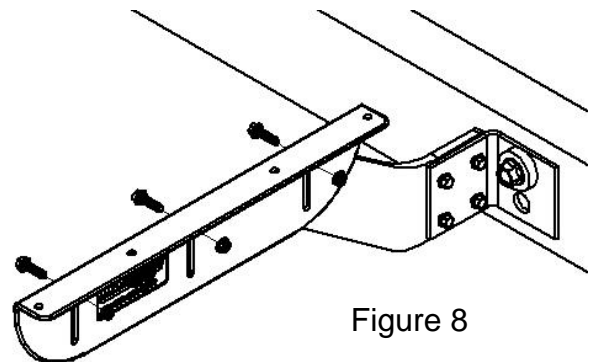

Figure 8

G. Drill four 5/16" holes through the fender using the holes in bracket PB5071 as a pattern (Figure 9).

- a. Install the 5/16" x 1 1/4" bolts through the bracket and into the fender.
- b. Use 5/16" fender washers and 5/16" nuts provided with the kit on the underside of the fender.
- c. **Recommended torque for all 5/16" bolts is 10-15 ft-lbs.**

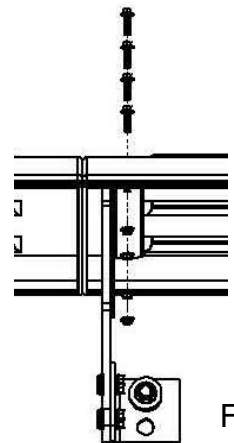

Figure 9

H. If possible, position the mounting brackets so they are located within 15" of the bottom of the fender. This protects against wind blowing the leading edge of the fender back into the tire (Figure 10).

Tip: If the front fender bracket is mounted higher than 15", refer to <http://www.minimizer.com/instructions.html> for further suggestions on adding additional support.

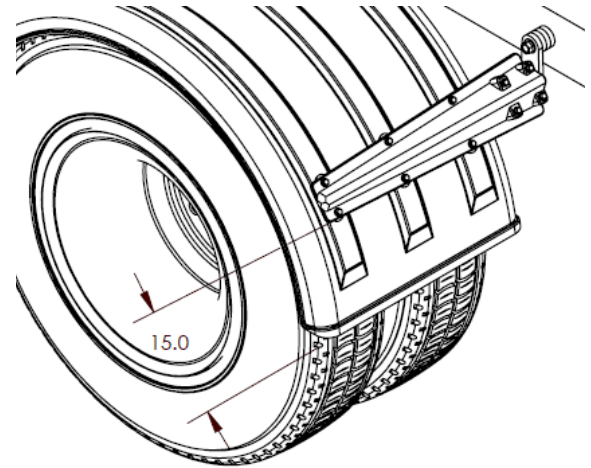

Figure 10

STEP 5

A. Use four 5/16" x 3" bolts to attach the bracket (part number PB501026) and the backing block (part number PBLOCK) to the steel swivel (part number PB5015). See Figure 11. **Make sure the steel swivel is fully inserted into the bracket.**

TIP: USE CARE WITH POWER TOOLS AS OVER-TORQUING WILL CAUSE CRACKS IN THE BRACKET. RECOMMENDED TORQUE IS 10-15 ft-lbs.

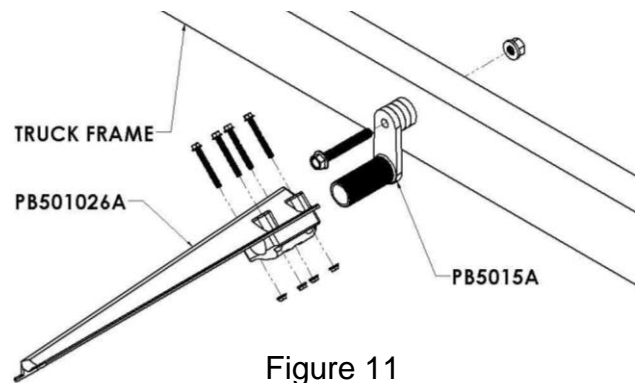

Figure 11

NOTE: DO NOT EXCEED RECOMMENDED TORQUE. THIS WILL VOID THE WARRANTY.

TIP: Do not completely tighten one side of the backing block before moving to the other side. Alternate tightening bolts as pictured in Figure 12. Make sure to only tighten halfway and then repeat the pattern in Figure 12 until backing block is tight.

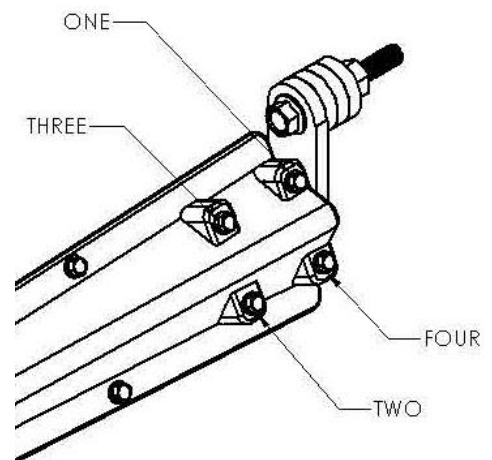

Figure 12

STEP 6

- A. Once the brackets are placed in position with the fender, securely tighten the 5/8" x 4-1/2" bolts that go through the PB5015 steel swivel to attach the swivel securely to the frame (Figure 13). **Recommended torque is 160-170 ft-lbs.**

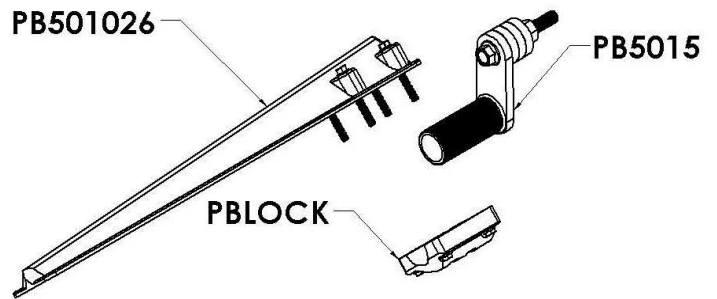

Figure 13

STEP 7

- A. Attach the bracket (PB501026A) to the fender.
- Drill six 5/16" holes through the fender using the holes in bracket PB501026A as a guide.
 - Install the 5/16" x 1" bolts through the bracket and into the fender.
 - Use six 5/16" fender washers and 5/16" nuts provided with the kit on the underside of the fender.
 - Tighten the bolts to recommended torque of 10-15 FT-LBS.** Hand tightening with Torque wrench is recommended. **DO NOT EXCEED RECOMMENDED TORQUE.**
 - Make sure the fenders are square and aligned (Figure 14). Twists or bows in the fender will fatigue the material over time.

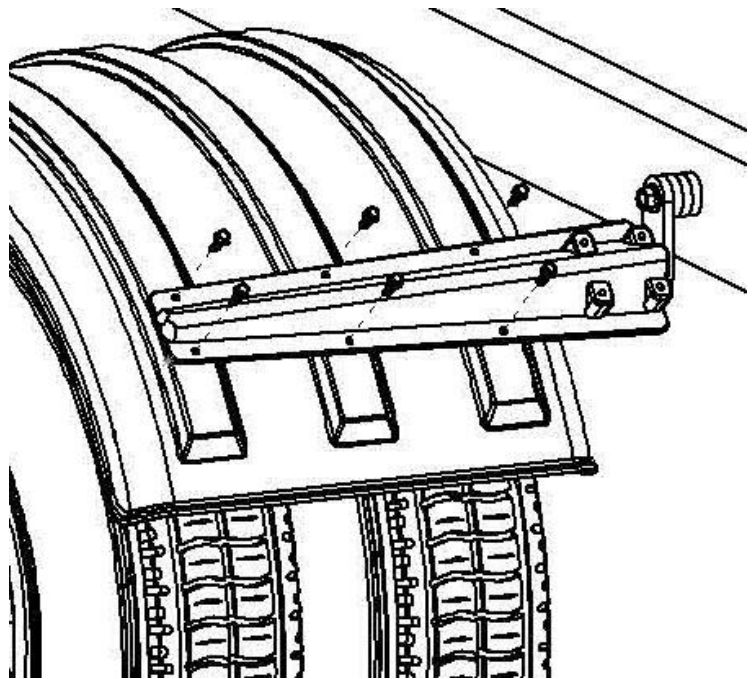

Figure 14

STEP 8

- A. For trucks with air suspension, raise and lower the suspension one final time to confirm that there is adequate clearance between the fenders and wheels.
- B. Recheck all brackets and bolts to ensure they are tightened to the recommended torque.

NOTE: ONCE FENDERS ARE IN SERVICE OCCASIONALLY CHECK TORQUE ON 5/8" X 4-1/2" HEX BOLTS IN THE FRAME TO MAKE SURE THEY DO NOT LOOSEN OVER TIME.

ZONE		REVISIONS		DATE	APPROVED
REV.	DESCRIPTION				

IMPORTANT INFORMATION

Assemble a left hand and right hand arm assembly as shown. The bolt head (MUST) be on the metal plate side. The serration on the bottom of the bolt head will damage the plastic arm. Use the nut on the plastic arm side. Tighten from the bolt head side so the nut does not spin on the plastic arm. If the locknut is ever loosened after it has been tightened it is highly recommended to replace the locknut.

RECOMMENDED TORQUE FOR ALL 5/16 HARDWARE IS 10-15 FT-LBS
CAUTION: OVERTIGHTENING THE HARDWARE WILL DAMAGE THE PLASTIC ARM AND COULD CAUSE IT TO FAIL

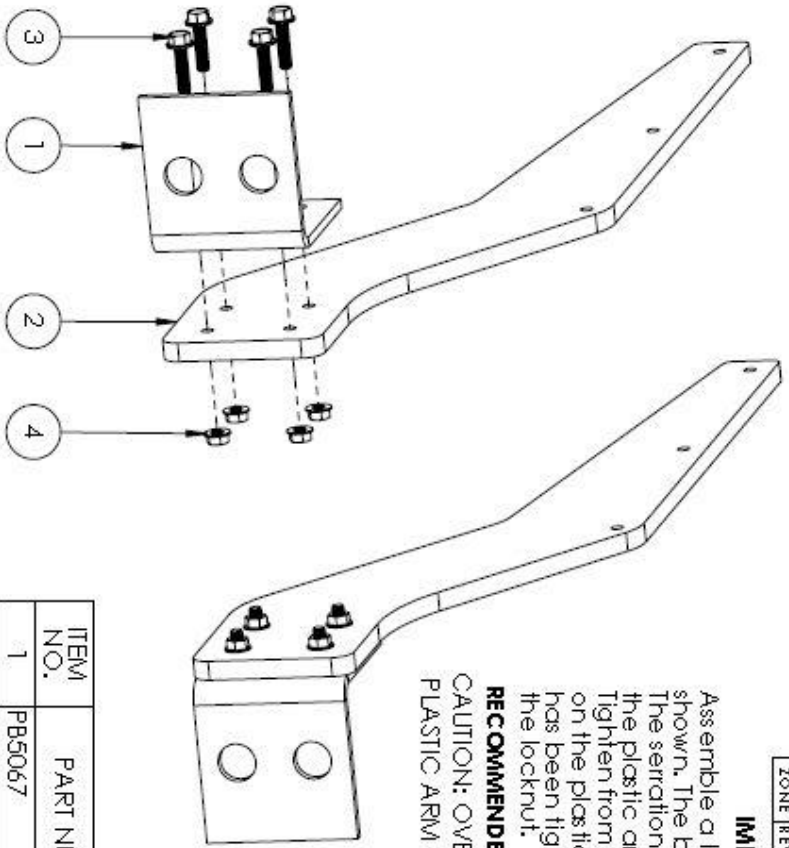

ITEM NO.	PART NUMBER	DESCRIPTION	QTY.
1	PB5067	BRKT,5067STL,CNTR,ANGL	2
2	PB5069	BRKT,5069,PE,CNTR,.5	2
3	I31C125BSF/RBZ	HDWR,HHC,S,RBZ,SERR,5/16-18X1.2	8
4	I31C125BSF/RBZ	HDWR,NUT,RBZ,FLNG-LOCK,5/16-18	8

DATE BY: 3/29/2016	BY: TRAP	UNITS: CHANGES SPECIFIED	SHEET: A	PART NO: B5068A-B5070A	REV: 1
DATE BY: REFER TO PRINT	BY: REFER TO PRINT	DIMENSIONS: ALL DIMENSIONS IN INCHES	SCALE: 1:1	WEIGHT: NA	SHEET 1 OF 1
DATE BY: REFER TO PRINT	BY: REFER TO PRINT	1/8" DIA. HOLE POSITION TOLERANCE: .015"	SPRAY CONTROL SYSTEMS INC. BLOOMING PRAIRIE, MN 55917 DESCRIPTION: PLSTC, CNTR, BRKT, ASSY, INSRT		
1/8" DIA. HOLE POSITION TOLERANCE: .015" 1/16" DIA. HOLE POSITION TOLERANCE: .010" 1/32" DIA. HOLE POSITION TOLERANCE: .008" DIMENSIONS: ALL DIMENSIONS IN INCHES					
1/8" DIA. HOLE POSITION TOLERANCE: .015" 1/16" DIA. HOLE POSITION TOLERANCE: .010" 1/32" DIA. HOLE POSITION TOLERANCE: .008" DIMENSIONS: ALL DIMENSIONS IN INCHES					