

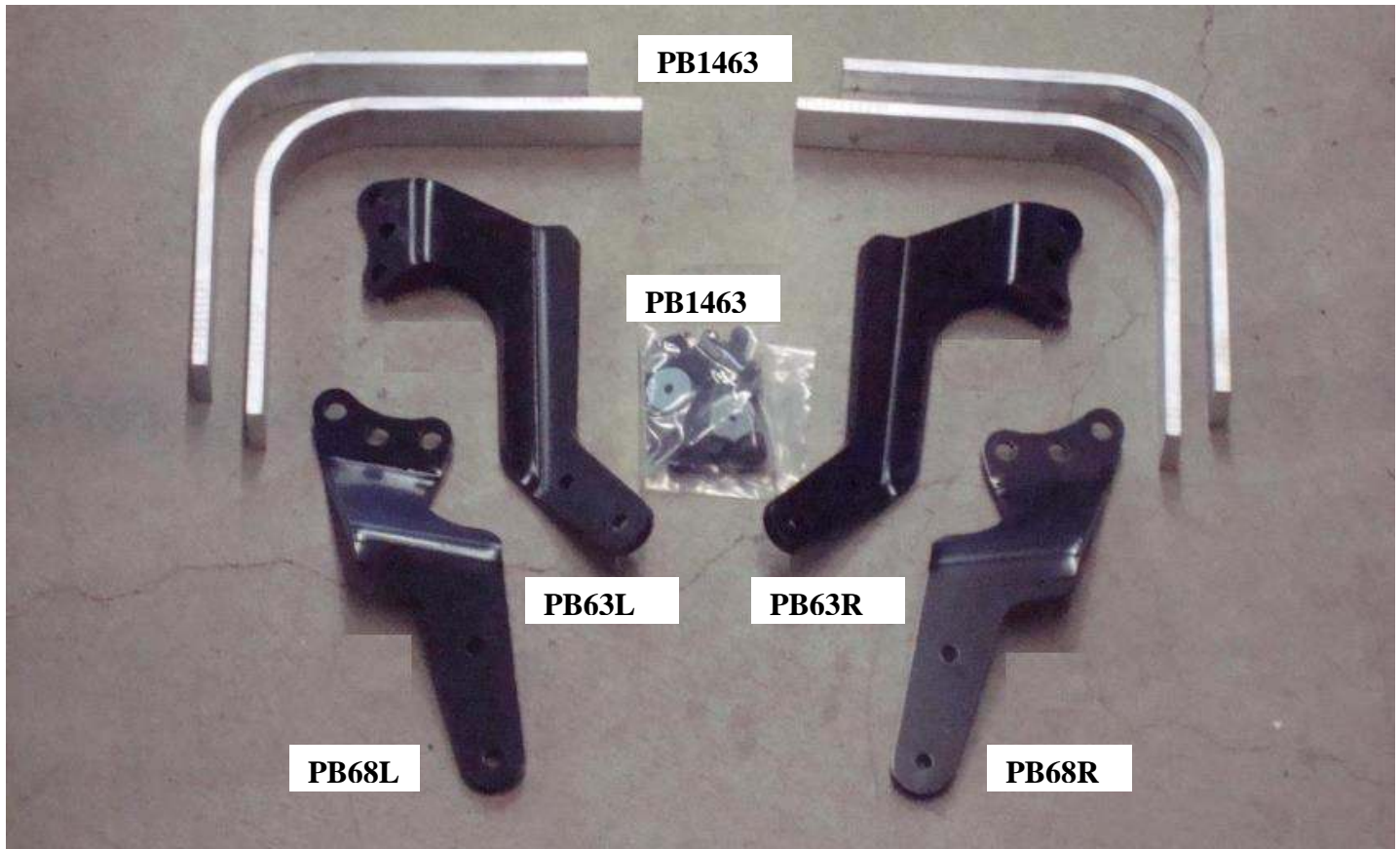

**INSTALLATION INSTRUCTIONS
STEERABLE AXLE BRACKET KIT
FOR Eaton 2 Bolt Cam Flange Rear Mount
Kit# B868SBA**



*****BOLTS ARE ONLY PROVIDED FOR STEPS 8- 10. BOLT SIZES VARY IN STEPS 1-7 DEPENDING ON THE APPLICATION AND ARE NOT PROVIDED.***

1. Remove the hub and drum assembly (with outboard hubs, you may only have to remove the drum).
2. Remove the lower three backing plate to spindle bolts on the rear side of the spindle.
3. Install the PB68L/R mounting plate with longer grade 8 bolts and 2 to 6, SAE flat washers between the spindle and the offset mounting plate. (This is to get the plate away from the irregular surface). The other mounting plate, PB63L/R is to be bolted in the lower 3 holes on the front side of the spindle using the same amount of spacer washers as the rear brackets.
4. Re-install hub and drum assembly.
5. Install tire and wheel.
6. Cut 12-1/2" leg to 10" (out to out) on all 4 aluminum arms (for 12" wide Fenders. NOTE – MAY HAVE TO CUT ARMS ACCORDINGLY – MEASURE CORRECTLY FIRST BEFORE CUTTING.



7. Hold rear arms in place with 10" leg over tire 1-1/2" from tire tread to inside of arm. Tim other leg to fit onto bracket (on inside, between bracket and truck frame.)
8. Clamp in place with vice grip (make sure inside of arm points directly to center of spindle.) Mark and drill 1/2" holes in aluminum arms. Bolt aluminum arm to steel mounting bracket using 1/2" bolts with self-locking nuts (provided in kit).
9. Mount the front arms to the PB78L/R brackets in the same manner as the rear.
10. Install the fender on top of the aluminum arms. Roll fender until it is approximately the same distance from end of the fender to the 2" arm on both ends of the fender. Make sure fender is parallel to tire. Drill 2 each 5/16" diameter holes on 6" centers (approximately 3" left and right of center) to bolt the fender to the arm. Use 5/16" bolts w/self locking nuts (provided in kit).

Recommended Placement of Brackets and Fenders for Correct Installation

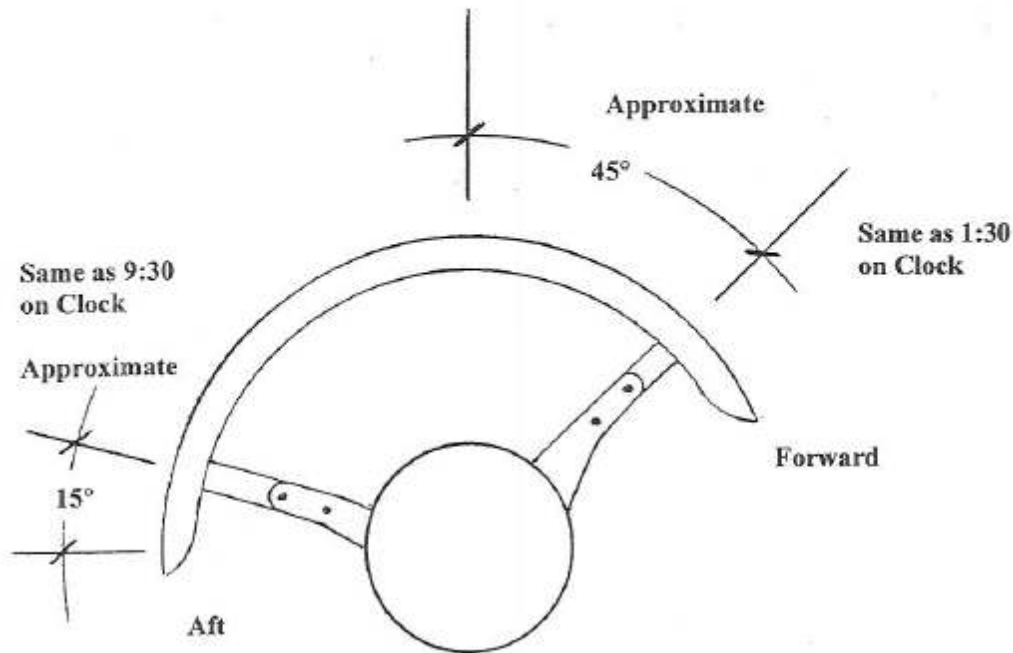

Instructions for use of MIN221800 fenders with Minimizer steerable lift axle brackets:

- Inside the Minimizer bracket kit locate four steel plates (Minimizer part number 100447)
- The steel plates are to be installed on the exterior surface of the fender.
 - Align the steel plate so it is even (top to bottom) with the aluminum arm. Use one plate for each aluminum arm.
 - Drill two 21/64" holes through the fender using the steel plate as a template
 - Drill two 21/64" holes in the aluminum arm using the fender and steel plate as a template.
 - Use the 5/16-18"x 1-1/4" hardware provided by Minimizer to fasten the fender in between the aluminum arm and the steel plate.
 - **Tighten the 5/16-18X1-1/4 bolts to a recommended torque of 5-7 ft-lbs. Do not exceed the recommended torque.**
- Failure to install the exterior steel plates at the time of installation will void the manufacturer's warranty on the MIN221800 fender component.
- If installing fender model MIN161200 or any model other than MIN221800, the steel plates are not necessary and may be discarded.

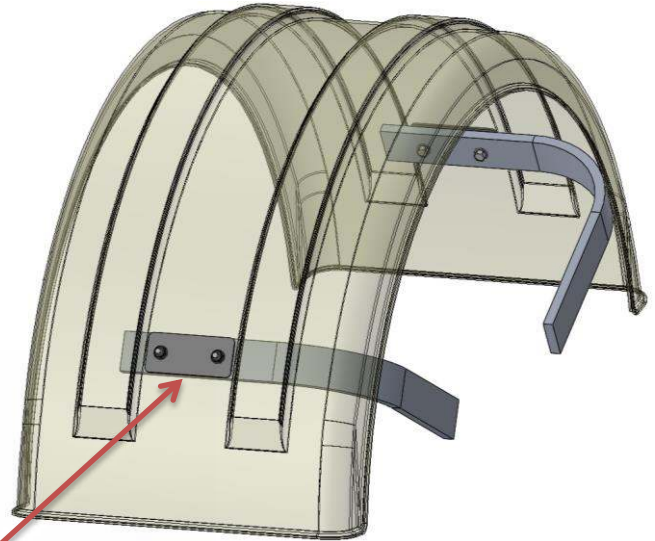
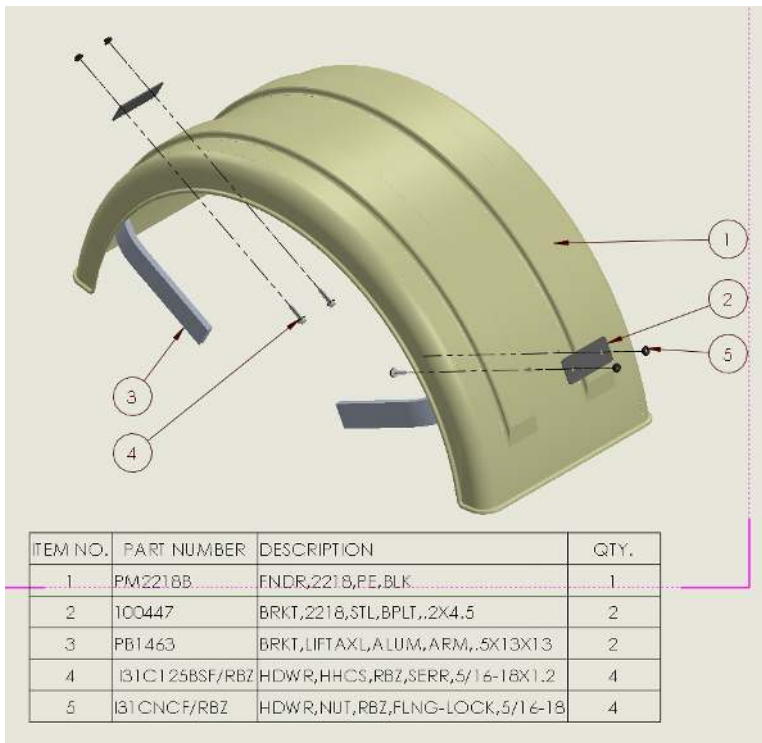

ALIGN STEEL PLATE WITH ALUM ARM

