

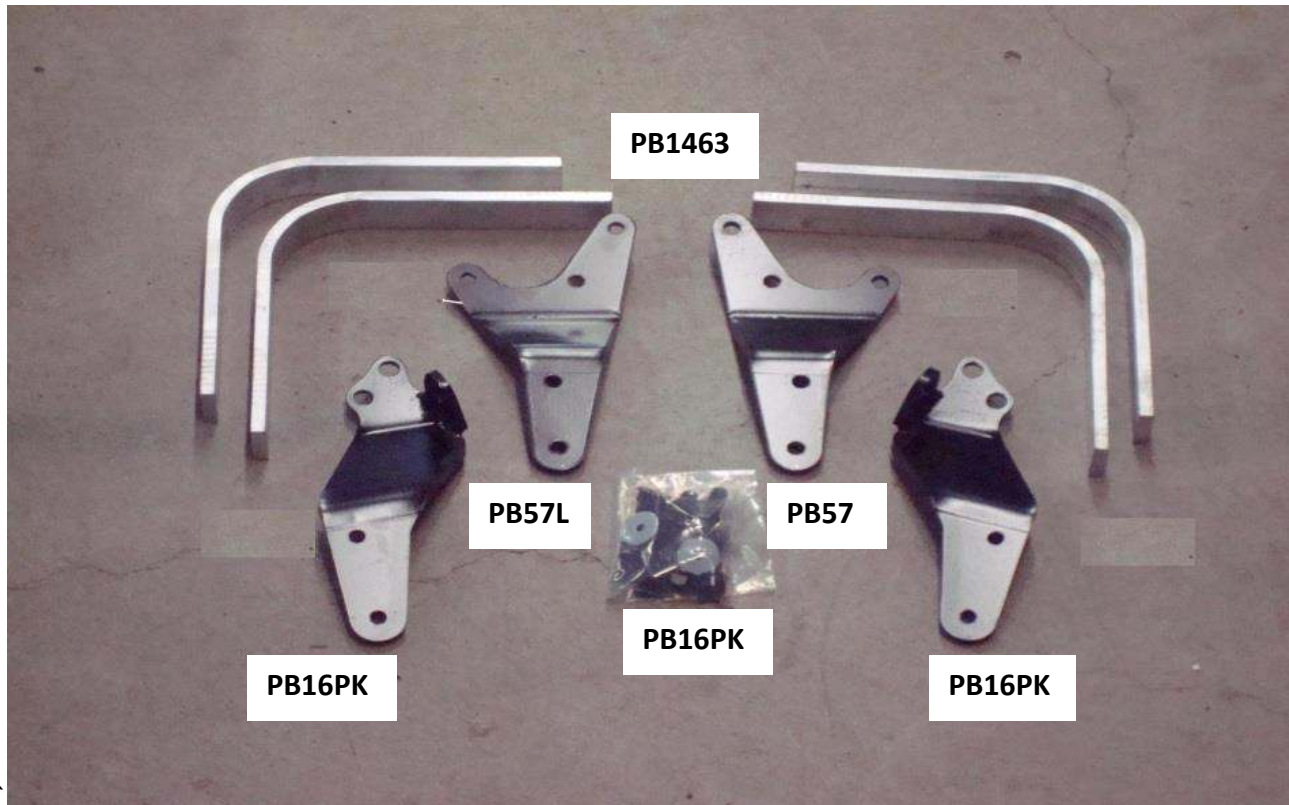

**INSTALLATION INSTRUCTIONS
LIFT AXLE FENDER BRACKET KIT**

**For Hendrickson HLUS-2, Fabricated Axle with 2 Piece Spindle & Eaton Four-Bolt Forward Cam
Flange
Kit# B8557SBA**



****BOLTS ARE ONLY PROVIDED FOR STEPS 12-13. BOLT SIZES VARY IN STEPS 1-11 DEPENDING ON THE APPLICATION AND ARE NOT PROVIDED.**

1. Remove the brake drum.
2. Remove the lower two 5/8" bolts on the rear side of the spindle.
3. Remove the 3/4" bolt in the steering arm that attaches the horizontal stabilizer.
4. Install 5/8" x 3" long grade 8 bolts in the lower two spindle holes with 3 each 5/8" SAE flat washers on the top bolt and 1 each on the lower bolt.
5. Install 3 each 3/4" SAE flat washers in the counter bore of the steering arm.
6. Install the 016-22-785 bracket. (All of the washers are installed "first" as spacers before installing the 016-22-785 bracket.)
7. Re-install the horizontal stabilizers with 3/4 x 5" grade 8 bolts and tighten all the nuts. Note: The first stabilizer can be installed easily by shifting the tie rod to one side. To install the second stabilizer, the use of a small come-along or ratchet strap to compress the first stabilizer makes the job much easier.



8. The mounting plate 016-22-57 is to be bolted to the cam tube-mounting flange. Use both top bolt holes and one lower bolt hole with $\frac{1}{2}$ " longer bolts.
9. Re-Install the brake drum. & tire & wheel.
10. Cut 12 – $\frac{1}{2}$ " leg to 10" (out to out) – or to desired length on all four aluminum arms.
11. Hold arms in place with 10" leg over tire 1 $\frac{1}{2}$ " from tire tread to inside of arm. Trim other leg to fit onto bracket (on inside, between bracket and truck frame).
12. Clamp in place with vise grip. (Make sure inside of arms point directly to center of spindle.) Mark & drill $\frac{1}{2}$ " holes in aluminum arms. Bolt aluminum arms to steel mounting brackets using $\frac{1}{2}$ " bolts with self-locking nuts (provided in kit).
13. Install poly fender on top of the aluminum arms. It should be approximately the same distance from the end of the fender to the 2" arm on both ends of the fender. Make sure the edge of the fender is parallel to the side of the tire. Drill two each $\frac{5}{16}$ " diameter holes into center of fender ribs to bolt the fender to the arm. Use $\frac{5}{16}$ " bolts with self-locking nuts (provided in kit).

Recommended Placement of Brackets and Fenders for Correct Installation

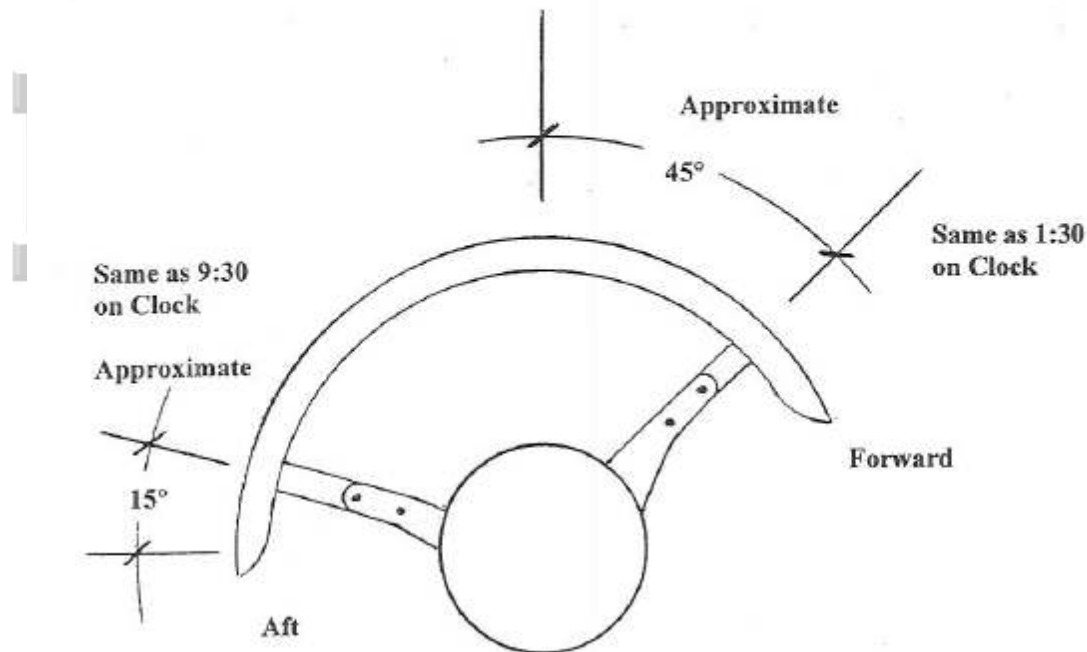

Instructions for use of MIN221800 fenders with Minimizer steerable lift axle brackets:

- Inside the Minimizer bracket kit locate four steel plates (Minimizer part number 100447)
- The steel plates are to be installed on the exterior surface of the fender.
 - Align the steel plate so it is even (top to bottom) with the aluminum arm. Use one plate for each aluminum arm.
 - Drill two 21/64" holes through the fender using the steel plate as a template
 - Drill two 21/64" holes in the aluminum arm using the fender and steel plate as a template.
 - Use the 5/16-18"x 1-1/4" hardware provided by Minimizer to fasten the fender in between the aluminum arm and the steel plate.
 - **Tighten the 5/16-18X1-1/4 bolts to a recommended torque of 5-7 ft-lbs. Do not exceed the recommended torque.**
- Failure to install the exterior steel plates at the time of installation will void the manufacturer's warranty on the MIN221800 fender component.
- If installing fender model MIN161200 or any model other than MIN221800, the steel plates are not necessary and may be discarded.

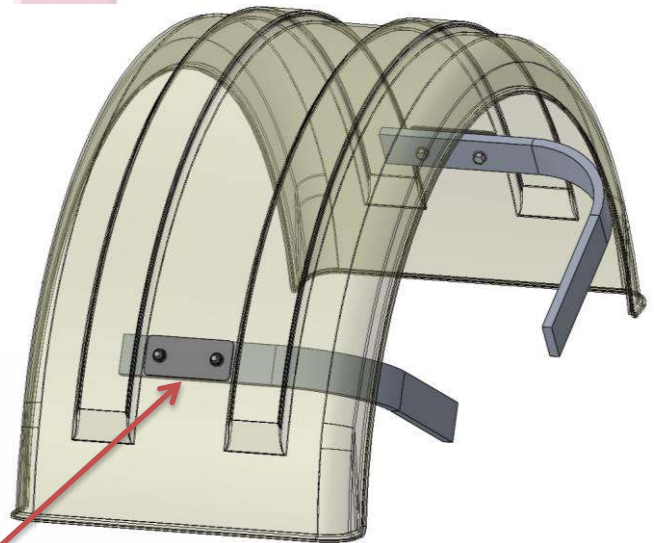
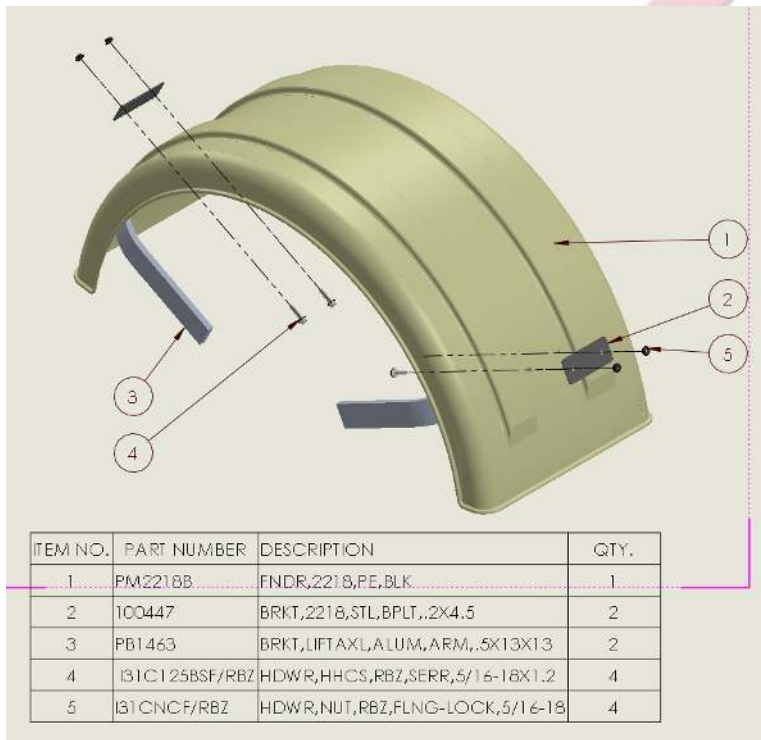

ALIGN STEEL PLATE WITH ALUM ARM

